

ISD1806B

The ISD1806B device offers 4 to 10 seconds duration depending upon the sampling frequency selected. Sampling frequency and duration are determined by an external resistor connected to the ROSC pin. The below table shows the relationship between sampling frequency, ROSC and duration.

Sampling Frequency	8 kHz	6.4 kHz	5.3 kHz	4 kHz
ROSC	80K	100K	120K	160K
Duration	4.7 secs	6.0 secs	7.5 secs	9.4 secs

FEATURES

- **Single power supply: 2.4V to 5.5V**
- **Ease-to-use single-chip, single-message voice record/playback solution**
- **Active low on all control inputs for operations**
- **High-quality, natural voice/audio reproduction**
- **Either level-hold or one-shot for recording operation**
- **Either edge-triggered or level-hold triggered for playback operation**
- **Optional beeping sound effects for recording operation**
- **100-year message retention**

TYPICAL APPLICATION CIRCUIT

The following typical application examples on ISD1806B series are for references only. They make no representation or warranty that such applications shall be suitable for the use specified. Each design has to be optimized in its own system for the best performance on voice quality, current consumption, functionalities and etc.

It is important to have a separate path for each ground and power back to the related terminals to minimize the noise. Besides, the power supplies should be decoupled as close to the device as possible.

ISD1806B

Example #1: LED output is employed

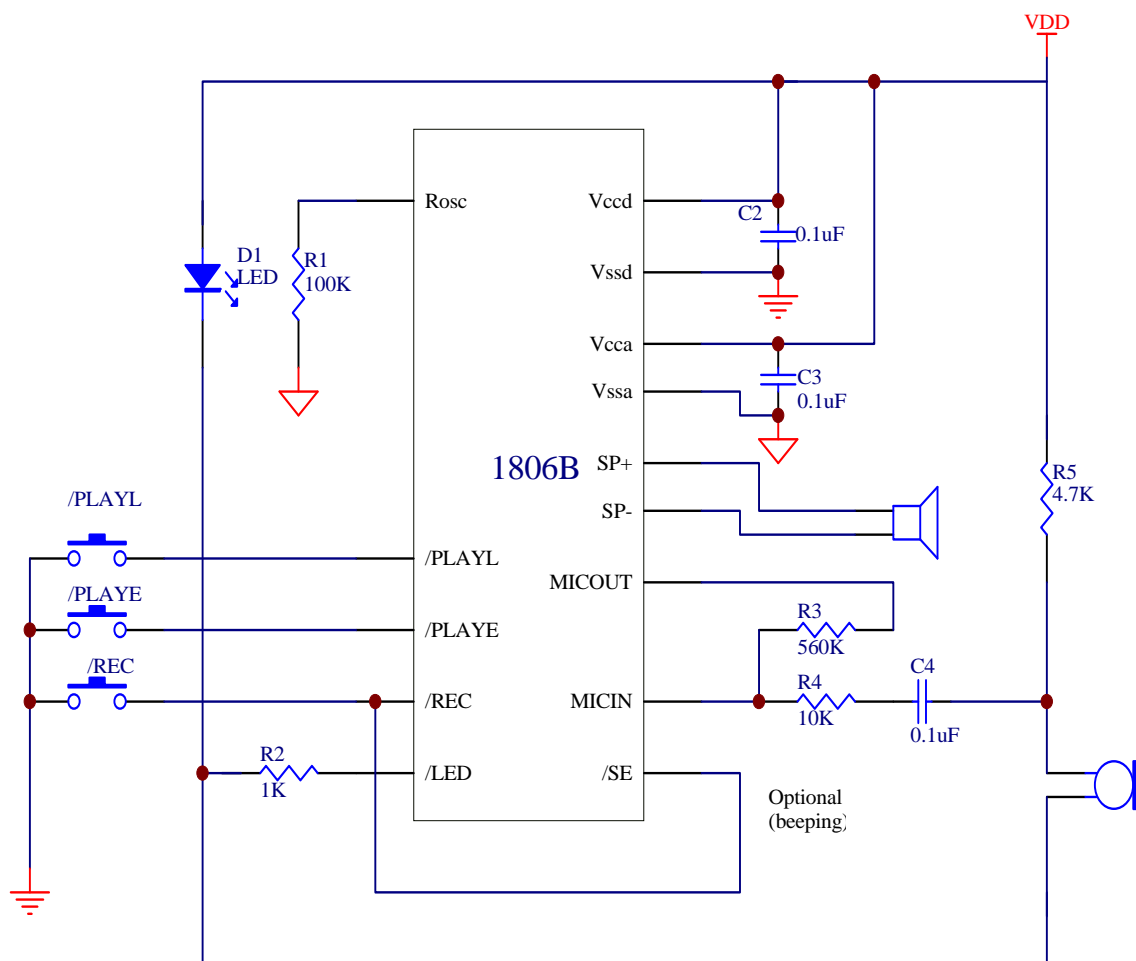

注：R2可省去。

ISD1806B

Example #2: LED output is not used

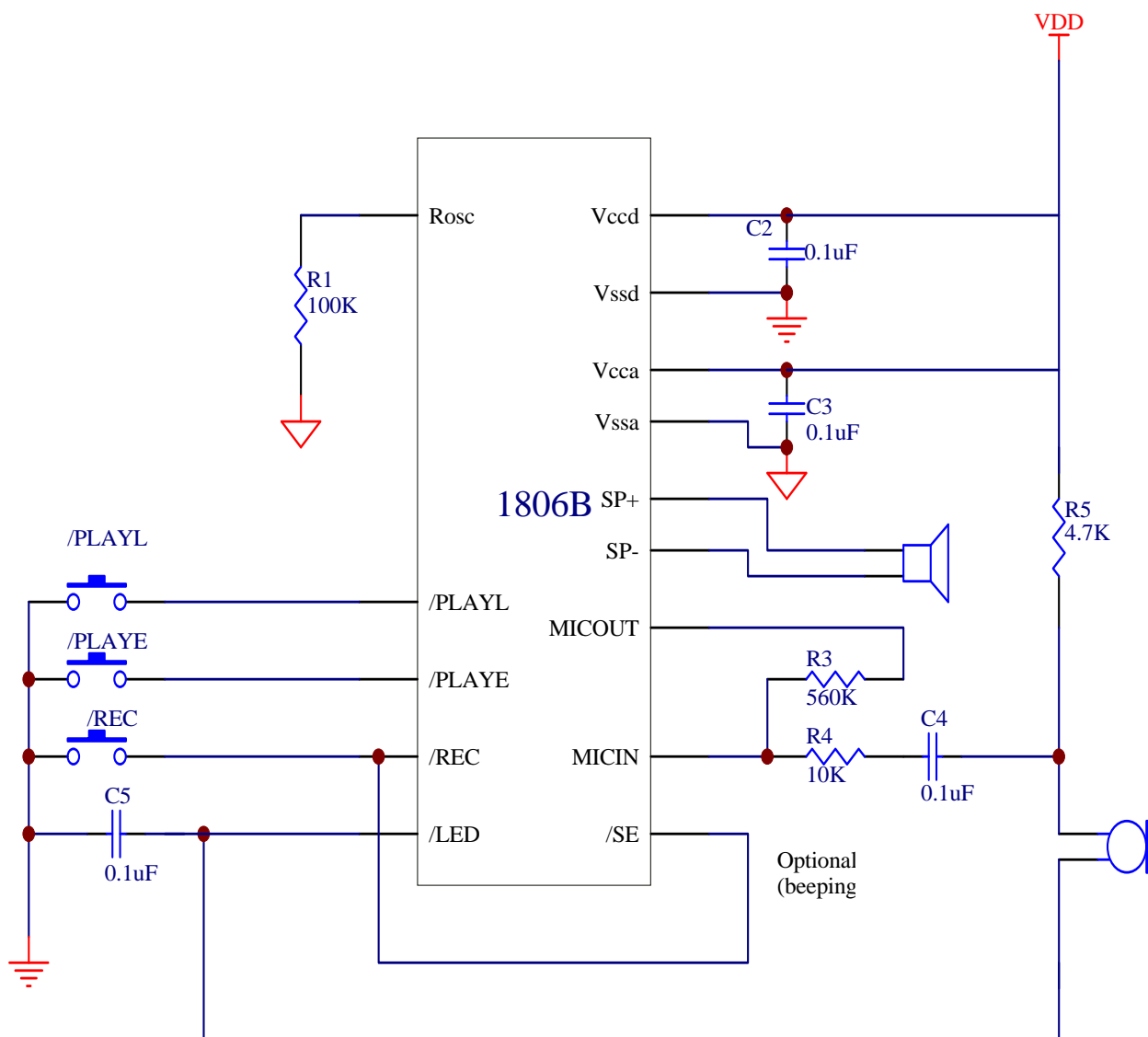

注：C5可省去。

ISD1806B Die Information

ISD1806B

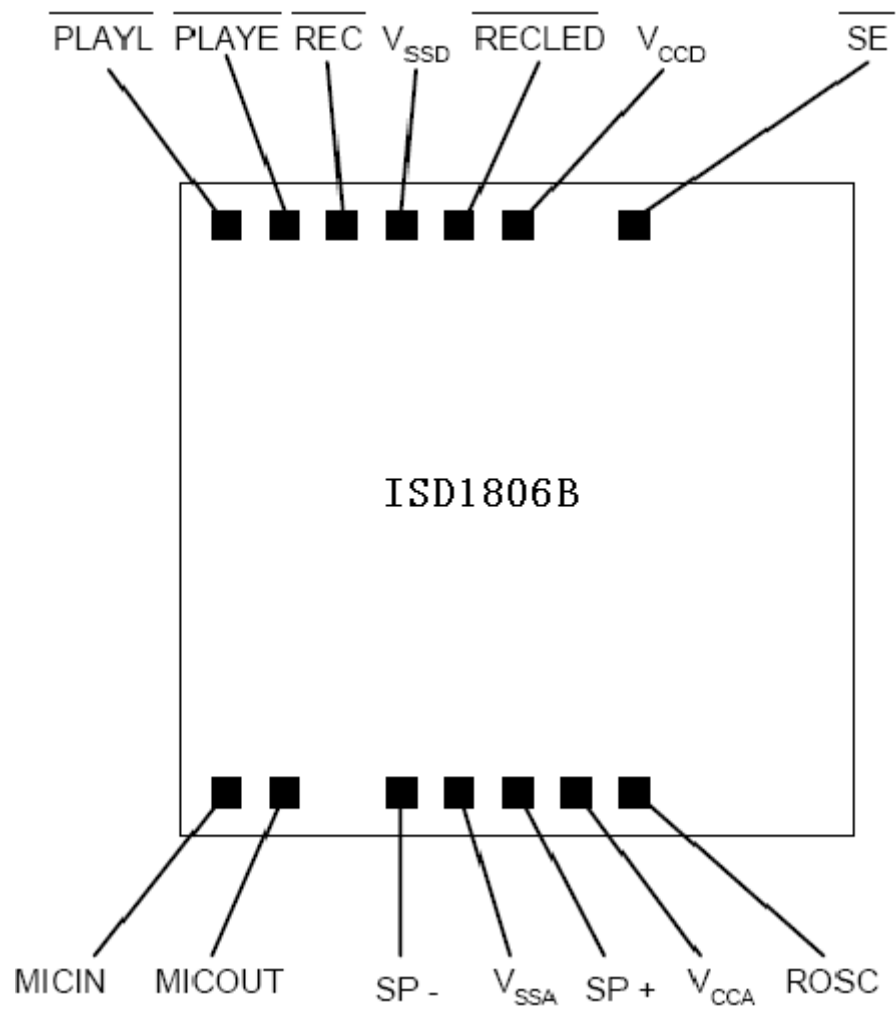

ISD1806B

Pad Name	X coordinate	Y coordinate
	[um]	[um]
\overline{SE}	630.45	1018.90
VCCD	122.15	1038.70
\overline{RECLED}	-126.05	1038.70
VSSD	-368.95	1038.70
\overline{REC}	-558.98	1038.70
\overline{PLAYE}	760.15	1038.70
\overline{PLAYL}	-977.35	1038.70
MICIN	-977.75	-1037.20
MICOUT	-741.75	-1037.20
SP -	-148.15	-1024.10
VSSA	158.85	-1037.20
SP +	465.85	-1024.10
VCCA	772.85	-1037.20
ROSC	1007.05	-1037.20

Die Dimensions (Scribe line included): X: 2470 μm , Y: 1952 μm

Pad opening: Single: 90 x 90 μm

Notes:

1. (x,y) coordinates are referenced to the die center.
2. The backside of die is internally connected to V_{SS} . It **MUST NOT** be connected to any other potential or damage may occur.
3. Die thickness is subject to change, please contact Winbond factory for status and availability.

元件清单（共7个零件）：

104 电容 3个

100K 电阻 1个

560K 电阻 1个

10K 电阻 1个

4.7K 电阻 1个