



佑華微電子股份有限公司

AM4EB Series

DATA SHEET

佑華微電子股份有限公司

新竹市光復路二段 295 號 9 樓之 1 號

電話: 03-573 6660

傳真: 03-573 6661

www.ealpha.com.tw

Alpha Microelectronics Corp.

9F-1, 295, Sec. 2, Kuang Fu Rd., Hsinchu, Taiwan

Tel : +886-3-573 6660

Fax: +886-3-573 6661

www.ealpha.com.tw

1.0 General Description

The AM4EB series are very low cost voice and melody synthesizer with 4-bits CPU. They have various features including 4-bits ALU, ROM, RAM, I/O ports, timers, clock generator, voice and melody synthesizer, and PWM (Direct drive) output, etc. The audio synthesizer contains one voice-channel and two melody-channels. Furthermore, they consist of 27 instructions in these devices. With CMOS technology and halt function can minimize power dissipation. Their architectures are similar to RISC, with two stages of instruction pipeline. They allow all instructions to be executed in a single cycle, except for program branches and data table read instructions (which need two instruction cycles).

2.0 Features

- (1) Single power supply can operate from 2.2~5.5V at 4MHz or 3.6~5.5V at 8MHz.
- (2) Program ROM: 8k x 10 bits
- (3) 1 set of 15-bits DPR can access up to 32k x 10 bits melody data memory space, and 1 set of 15-bits VPR can access up to 32k x 10 bits voice data memory space.

Product	Voice Duration (sec)	Voice Pointer (VPR)	ROM Size (10-bit)
AM4EB005x	5	14-bits	16k
AM4EB010x	10	15-bits	32k

- (4) Data Registers:
 - a). 96 x 4-bits data RAM (00-5Fh)
 - b). Unbanked special function registers (SFR) range: 00h-2Fh
- (5) I/O Ports:
 - a). PRA: 4-bits I/O Port A (10h) can be programmed to input/output individually. (Register control)
- (6) On-chip clock generator: Resistive Clock Drive (**RM**)
- (7) Timer: 1-set Voice Interrupt (Timer0: a 9-bits auto-reload timer/counter).
- (8) Stack: 2-level subroutine nesting.
- (9) Built-in 4-level Volume Control can be programmed.
- (10) Built-in IR Carry Output: Port A[1] can be configured as IR pin by 38k / 56kHz. (Mask option)
- (11) External Reset: Port A[3] can be configured as reset pin. (Mask option)
- (12) HALT and Release from HALT function to reduce power consumption
- (13) Watch Dog Timer (**WDT**)
- (14) Instruction: 1-cycle instruction except for table read and program branches which are 2-cycles
- (15) Number of instruction: 27
- (16) DAC: 1 channel voice and dual tone melody synthesizer (One 8-bits PWM output).

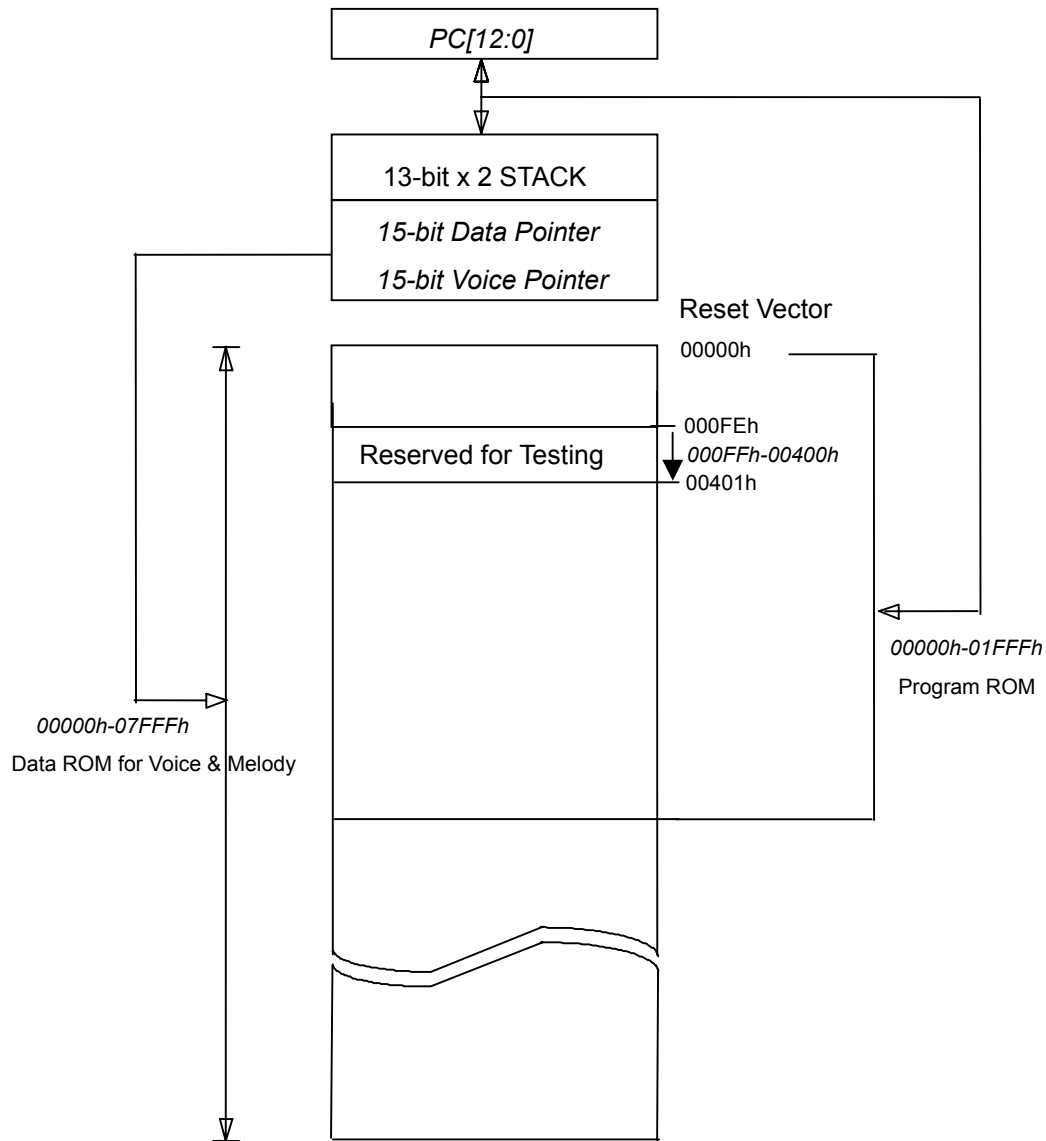
FIGURE 1 : ROM Map of AM4EB Series

3.0 Pin Description

Pad Name	Pin Attr.	Description
PWM2	O	PWM2 output.
PWM1	O	PWM1 output.
Vdd1~2	Power	Power supply during operation.
PRA0, PRA2	I/O	I/O port can be programmed to input/output individually. Input type with weak pull-low or fix-input-floating capability. Buffer Output type.
PRA1 / IR	I/O	I/O port can be programmed to input/output individually. Input type with weak pull-low or fix-input-floating capability. Buffer Output type. <i>Mask option selected as an IR Carrier Output with 38k / 56kHz</i>
PRA3 / Reset	I/O	I/O port can be programmed to input/output individually. Input type with weak pull-low or fix-input-floating capability. Buffer Output type. <i>Mask option selected as an external RESET pin with weak pull-low capability.</i>
OSC	I	RM mode Oscillator input
GND1~2	Power	Ground Potential

4.0 ABSOLUTE MAXIMUM RATING:

Symbol	Rating	Unit
Vdd~Vss	-0.5 ~ +7.0	V
Vin	Vss-0.3 < Vin < Vdd+0.3	V
Vout	GND < Vout < Vdd	V
Top (operating)	0 ~ +70	°C
Tst (storage)	-25 ~ +85	°C

5.0 DC Characteristics

Symbol	Parameter	Vdd	Min.	Typ.	Max.	Unit	Condition
Vdd	Operating voltage		2.2	3	5.5	V	Fosc=4MHz
Isb	Supply current	Standby	3		1	uA	4MHz, RM, HALT Mode
			4.5		1		
Iop	Supply current	Operating	3	1		mA	4MHz, RM, no load
			4.5	2.5			
Iih	Input current (Internal pull low)	3	4		uA	Input ports with weak pull-low	
		4.5	10				
Ioh	Output-high current	3	-4		mA	Voh=0.4V	
		4.5	-10			Voh=1.0V	
Iol	Output-low current	3	8.5		mA	Vol=2.0V	
		4.5	19			Vol=2.6V	
Ioh	PWM output current	3	-25		mA	Vdd=3V, Voh=2.4V	
Iol		3	25			Vdd=3V, Vol=0.6V	
dF/F	Frequency stability		-5		5	%	$\frac{F_{osc}(3v-2.4v)}{F_{osc}(3v)}$
dF/F	Fosc lot variation		-10		10	%	Vdd=3V, Rosc=430k, (~4MHz)

FIGURE 2 : Frequency vs. Rosc (at 3V)

Resistor (Rosc ohms)	110k	200k	300k	430k
Frequency (MHz)	14.84	8.25	5.54	3.92

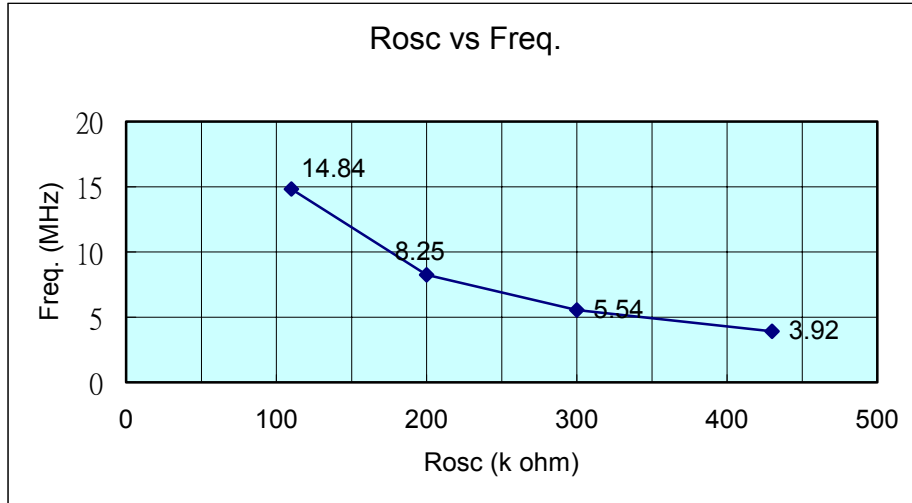

6.0 Application Circuit

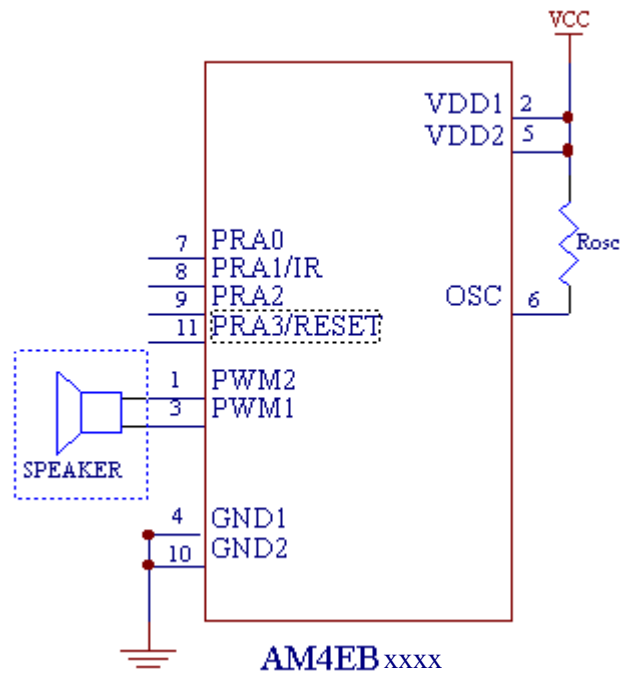

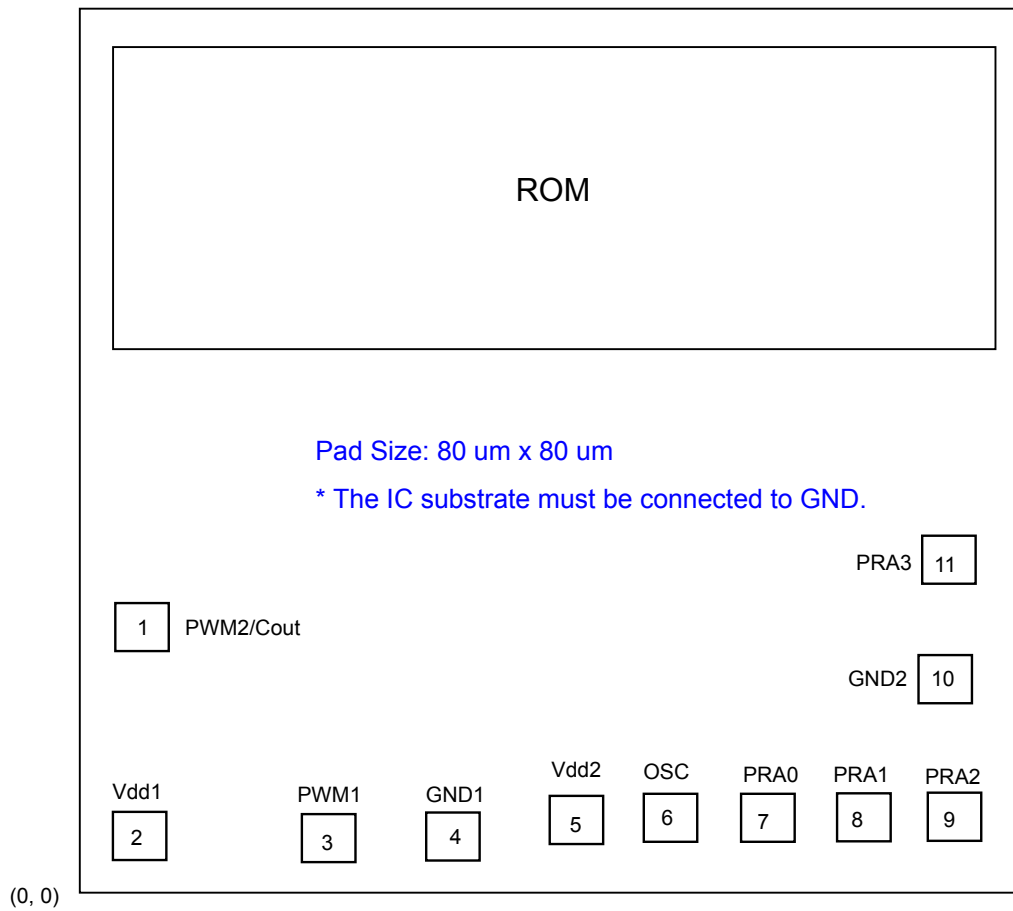
7.0 Bonding Diagram

Pad #	Pad Name	X	Y	Pad #	Pad Name	X	Y
1	PWM2	57	253	7	PRA0	785	87
2	Vdd1	58	58	8	PRA1	895	87
3	PWM1	253	57	9	PRA2	1005	87
4	GND1	404	58	10	GND2	995	231
5	Vdd2	565	87	11	PRA3	995	341
6	OSC	675	87				

Chip Size :

AM4EB0057 : 1166 um x 1094 um

AM4EB005D : 1170 um x 1100 um

AM4EB0107 : 1166 um x 1206 um